



# JAPAN FUJI INTERNATIONAL

We keep pursuing excellence and  
success in order to provide the best  
quality elevators to the world.





# INDEX

PRODUCTS	Passenger Lift & Home Lift	03
	Bed Lift	09
	Cargo Lift	10
	Escalator & Moving Walk	11
<hr/>		
PARTS	Ceiling	13
	Handrail	14
	Cabin & Floor Material	15
	COP & HOP	17
	Landing Doors	19
<hr/>		
OTHERS	Optional Function	21
	Functional List	23
<hr/>		
LAYOUTS	Passenger Lift & Home Lift	25
	Bed Lift	29
	Cargo Lift	30

# ABOUT US

JFI is a renowned company distributing its quality products to more than over 30 countries across Japan, Singapore, Southeast Asia, the Middle East, North America, Central and South America, and Africa. JFI has its production base located in Japan, and has been tested by legitimate authorities all around the world. It includes European standard, CE, Japanese relevant standards. Moreover, to ensure the best quality, we adopt machines from Amada(Japan) in our manufacturing factory. Further, through the international marketing strategy, we successfully achieve our goal to have our elevators seen by people all around the world.

## 社長のあいさつ

当社は「日本品質を世界へ」を目的に安全安心なエレベーターを世界へ供給しております。  
 私自身、日本国内で創業45年のエレベーター会社を営んで参りました。  
 その経験と製造会社・メンテナンス会社の協力体制をもって、世界の皆様へ  
 日本品質エレベーター JapanFuji をお届けします。



社長 大田英紀

## Words from President Ota

We supply safe elevators with Japanese quality to the world.  
 I myself have been in the business for 30 years in Japan.  
 We always deliver elevators with Japanese technologies and quality to the world.





## Intergrative Car Design



### Black Plating

Ceiling: Mirror Stainless / Black Plating Mirror Stainless  
 Car Wall: Back Plating Mirror Stainless With Etching  
 Mirror Stainless  
 Floor: PVC Anti-sliding Floor Tiles  
 COP: CS01-EP01 (Full Length)



### Gold Plating

Ceiling: Mirror Stainless / Gold Plating Mirror Stainless  
 Car Wall: Gold Plating Mirror Stainless With Etching  
 Mirror Stainless  
 Floor: PVC Anti-sliding Floor Tiles  
 COP: CS01-EP01 (Full Length)



### Bronze Plating

Ceiling: Mirror Stainless / Bronze Plating Mirror Stainless  
 Car Wall: Bronze Plating Mirror Stainless With Etching  
 Mirror Stainless  
 Floor: PVC Anti-sliding Floor Tiles  
 COP: CS01-EP01 (Full Length)



### Hairline Stainless

Ceiling: Painted Steel  
 Car Wall: Hairline Stainless Steel  
 Floor: PVC Anti-sliding Floor Tiles  
 COP: CS06-EP02



### Pattern Steel

Ceiling: Painted Steel With Acrylic  
 Car Wall: Pattern Steel  
 Floor: PVC Anti-sliding Floor Tiles  
 COP: CS06-EP02



### Painted Steel

Ceiling: Painted Steel With Acrylic  
 Car Wall: Painted Steel  
 Floor: PVC Anti-sliding Floor Tiles  
 COP: CS06-EP02

## OBH

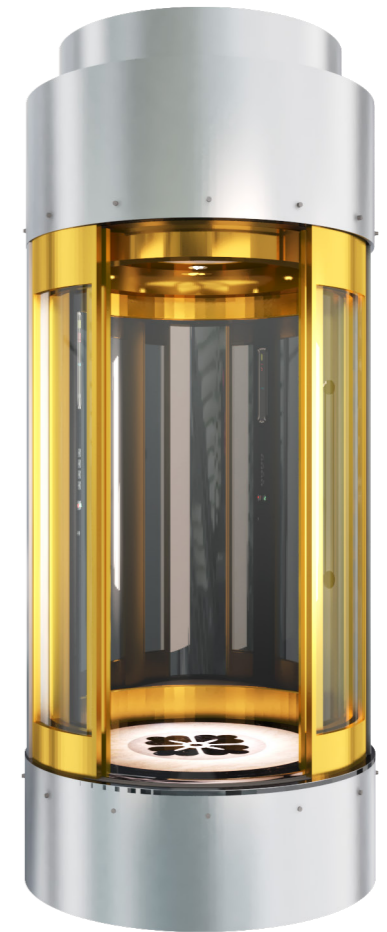

This OBH is the perfect solution for those who are looking for an elegant-looking elevator. The product will meet the needs for most homeowners, or others who do not need to transport large numbers of people at once. This round glass elevator is great for limited use. It's a stylish and economical of time and energy. This explains it is most liked by clients among our products.



## HAL Type

Elegant Reinforced Aluminum Alloy Shaft



### Specification

Ceiling: Mirror Stainless + Pattern Steel  
 Car Wall: Mirror Stainless + Pattern Steel + Glasses  
 Floor: PVC Anti-sliding Floor Tiles  
 COP: CS01-EP01

### Benefits

- No need to add the concrete shaft structure.
- Easy and quick installation for new and old houses.
- Little space is required for installation.
- It can be carried away when moving to new houses.
- Unlike common sheet steel, the exterior aluminum alloy cladding looks elegant and decent. It can easily match with original upholstery.
- It can become observation home lift by changing the exterior aluminum alloy cladding into glass.

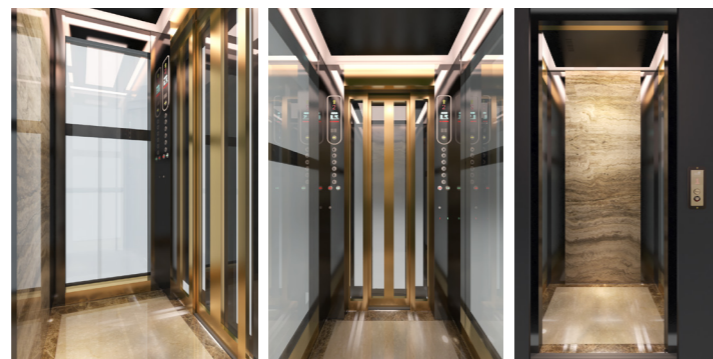

To install marble tiles by customers.

## G9 Pit Less Home Lift

### Luxury Specification

Shaft: Reinforced Aluminum Alloy Shaft + Glasses  
 Car Wall: Rose Gold Plating Vibration Stainless + Mirror Stainless + Glasses  
 Handrails: Leather  
 Floor: PVC Anti-sliding Floor Tiles  
 COP: LCD (I-Touch Type)



### Standard Specification

Shaft: Reinforced Aluminum + Aluminum Plates  
 Car Wall: Pattern Steel + Mirror Stainless  
 Handrails: Stainless  
 Floor: PVC Anti-sliding Floor Tiles  
 COP: LCD

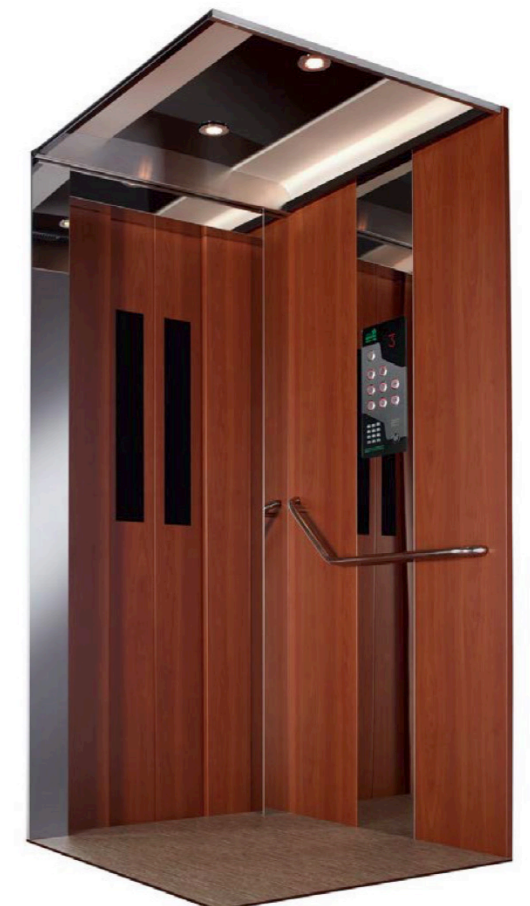



## Prestige Style

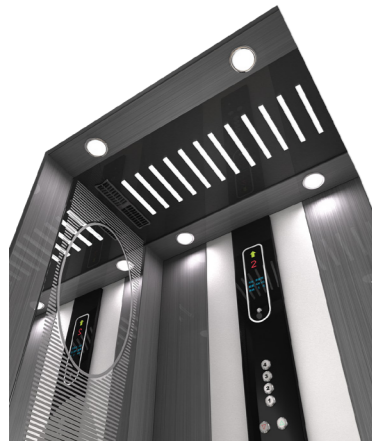

Energy saving LED lighting

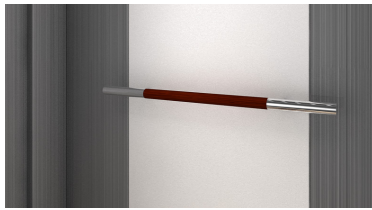

A stylish design of handrail



A modern touch of style with the latest architectural finishes



### Specification

Ceiling: Pattern LG001+Painted Steel  
 Car Wall: Pattern Steel LG001/SNA14 + Mirror Etching Stainless  
 Floor: PVC Anti-sliding Floor Tiles 505+509  
 COP: CS01-EP01

## Contemporary Style



Tinted mirrored finish and LED lighting for the ceiling



A handrail with stylish design



Cabin operating panel with LED display



### Specification

Ceiling: Pattern SNA14 + Painted Steel  
 Car Wall: Pattern Steel SNA-14  
 Floor: PVC Anti-sliding Floor Tiles 505+509  
 COP: CS01-EP01 (Full Length)



## Bed Lift

### Specification

Ceiling: Standard: ECL-502 ECL-503 ECL-504  
 Car Wall: Pattern Steel  
 Floor: PVC Anti-sliding Floor Tiles  
 COP: CS05-EP04 + CS09-EP09



HS05-EP04  
Wheelchair



CS09-EP09  
Wheelchair



ECL-501 (option)



ECL-502



ECL-503



ECL-504



## Cargo Lift

### Specification

Ceiling: Hairline Stainless Finish  
 Car Wall: Hairline Stainless Finish  
 Floor: Veined Pattern Steel Plate SUS  
 COP: CS05-EP04

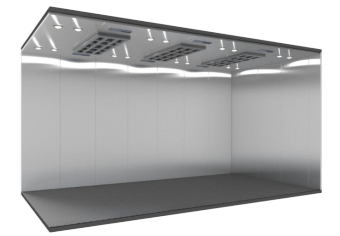



# ESCALATOR & MOVING WALK



JFI Escalator is widely used for places such as shopping centers, supermarkets, subways, airports, and etc. JFI escalator is equipped with the features such as the fine and exquisite structure, the premium step, the delicate belt, the remarkable outline model, and so on.



JFI moving walk not only solves the transport problems of huge passenger flows. Furthermore, it saves passengers a great amount of time, delivers luggage barrows, baby carts, shopping carts, and wheelchairs. JFI moving walk perfectly denotes the advanced technology, fine security, reliability, power, energy-saving, cozy, and smooth design idea for all of the users.

## Layout

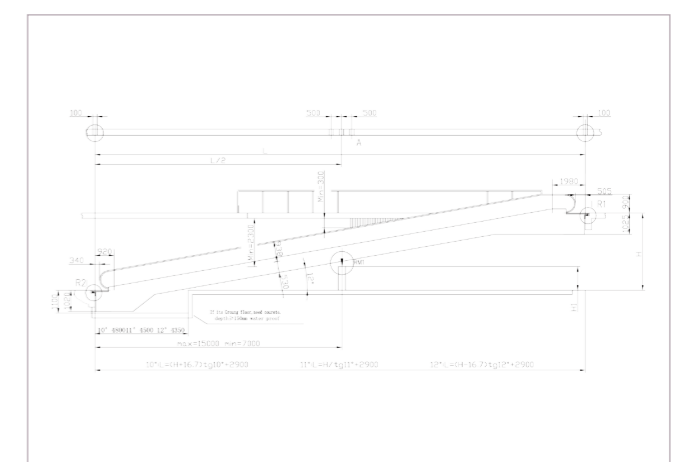
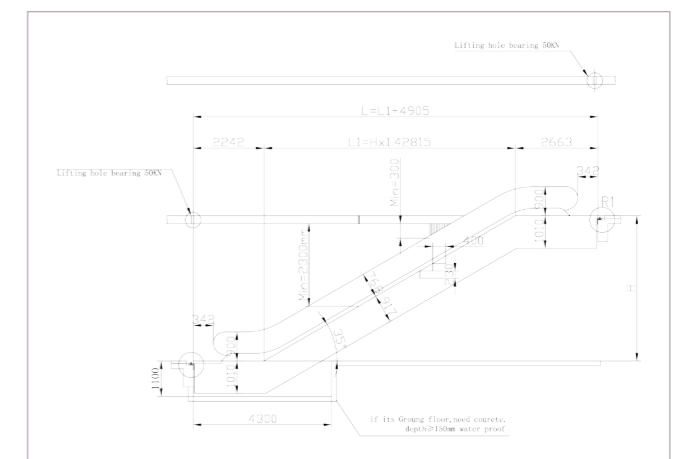
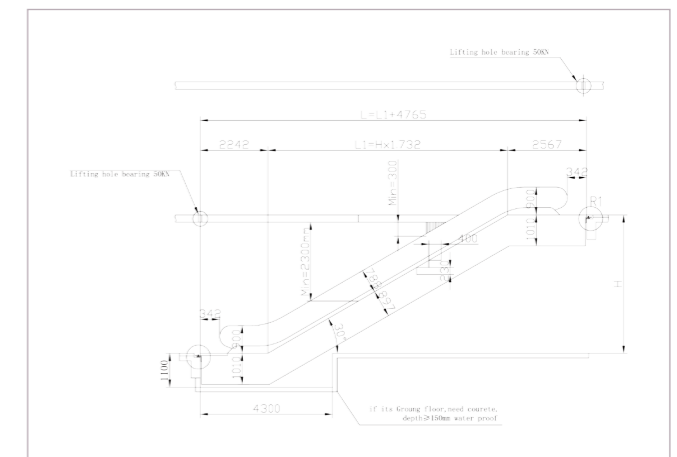



## CEILING

### STANDARD

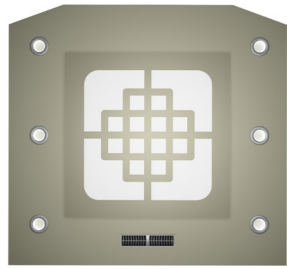

ECL-101  
Chinese style steel sheet coating

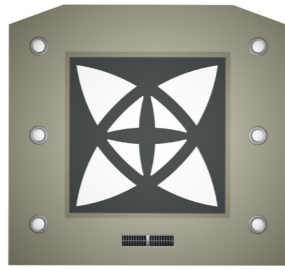

ECL-102  
Star-type steel sheet coating

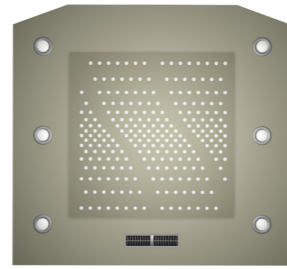

ECL-103  
Steel sheet coating of shooting star type

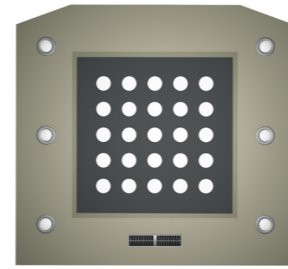

ECL-104  
Steel sheet coating of round-spot

### OPTIONAL



ECL-201  
Green forest type



ECL-202  
Red maple type



ECL-203  
Blue snowy type



ECL-204  
Starry night type



ECL-205  
Blue breeze type

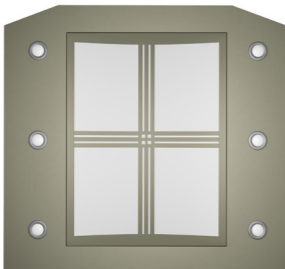

ECL-301  
Cross type arc shape sheet

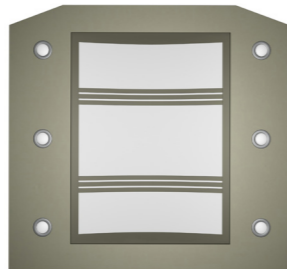

ECL-302  
Stripe type arc shape sheet

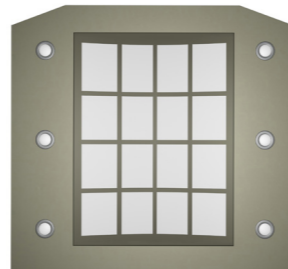

ECL-303  
Grid type arc shape sheet

## HANDRAIL



Luxurious type

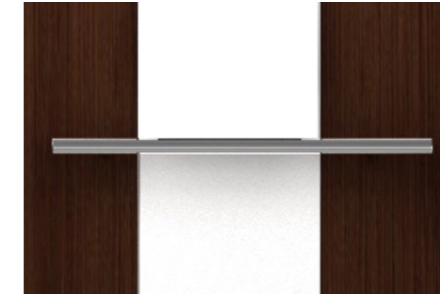

Single tube stainless steel type



L Type

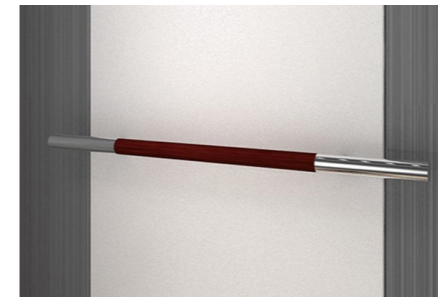

Prestige style



Round log and stainless steel composite type



Classic style



Grey leather type

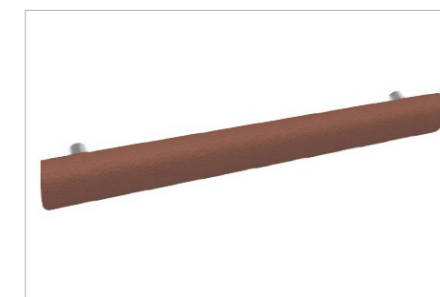

Dark rose leather type



Flat type



# CABIN & FLOOR MATERIAL

## FLOOR



PNK-001



PNK-002



PNK-003



PNK-004

## TILE



PVC-505



PVC-522



PVC-536



PVC-509

## PATTERN STEEL PLATE

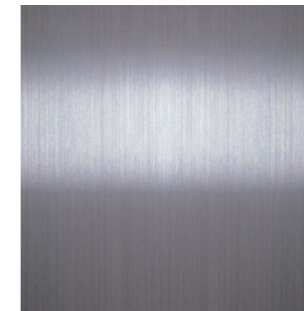

LP-LG001



LP-SNA15



LP-SNA24



LP-SNW1

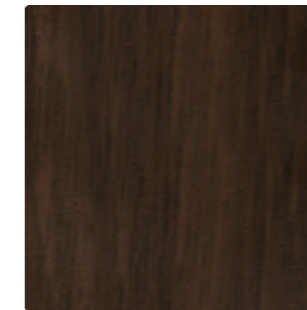

LP-SNW6



LP-SNW3



LP-SNA14

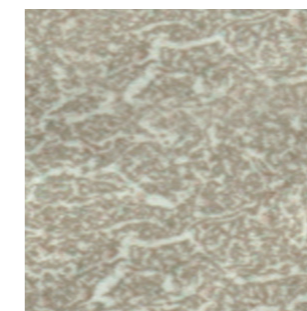

LP-C114



LP-C116



# COP & HOP

# LCD

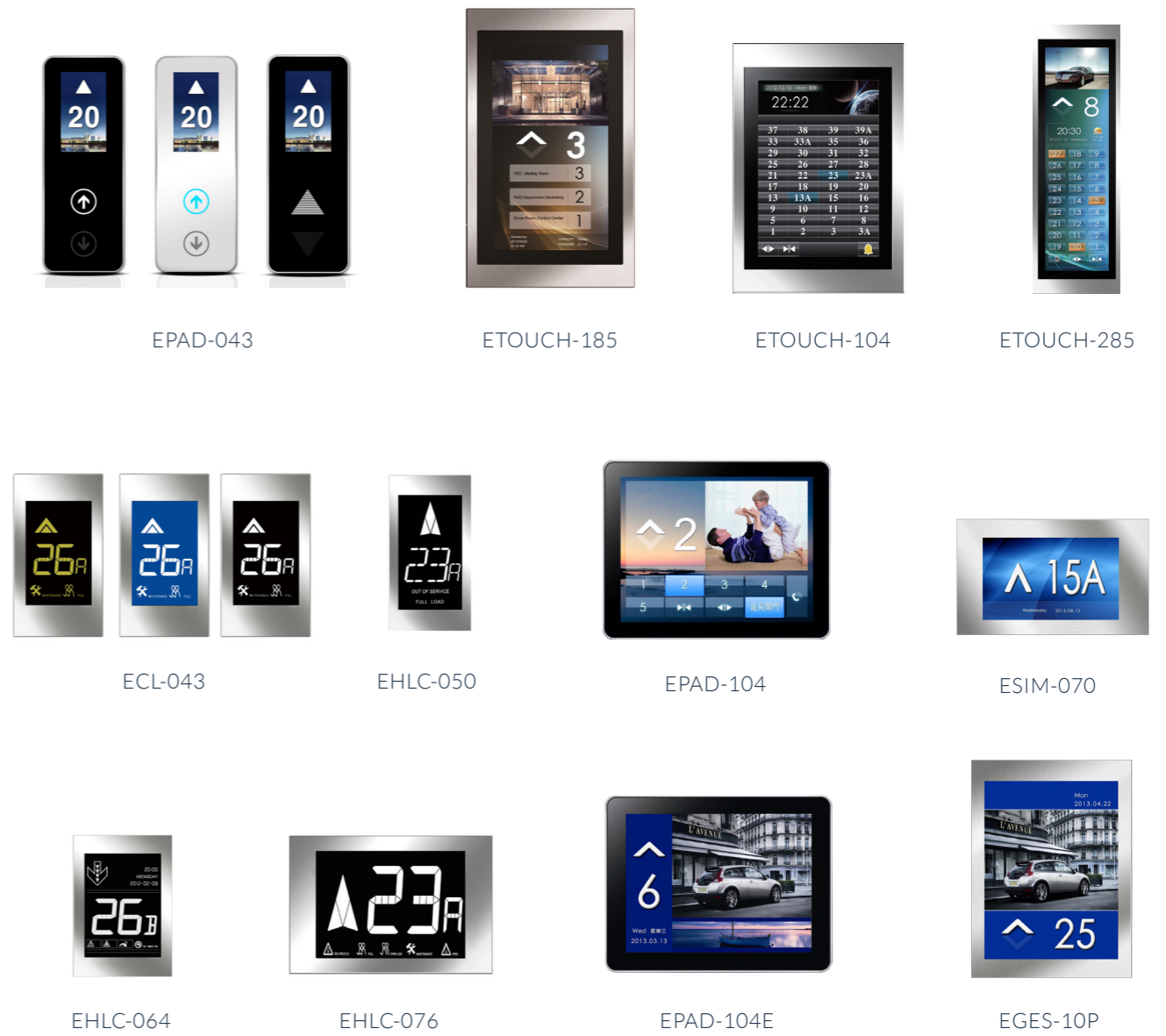



# LANDING DOORS

## STANDARD

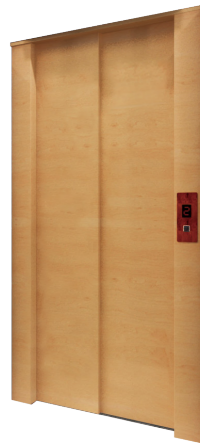

LSE-01



LSE-02



LSE-03



LSE-04

## GLASSES



LSE-005



LSE-006



LSE-007

## DOOR-OPENING



2S



CO



2CO



3CO



3S



2U

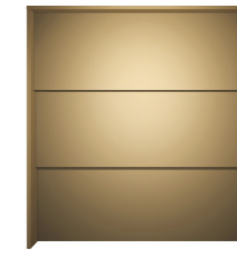

3U



Scissor Sliding Door



Fast Roller Door

## DOOR JAMB



Narrow Door Jamb



Wide Door Jamb



Transom



## UCMP

Unintended Car Movement Protection

When UCMP detects abnormal car movement more than 7.5 CM, it will instantly take brake action to stop the car movement.



## FLOOD DETECTION

When flood sensor detects water flows into pits, it will send signal to instruct elevators to move to a safe floor.

### FLOOD! NO PROBLEM!



## TWO IN ONE SAFETY EDGE

Two in one infrared Curtain and Mechanical Safety edge.

### Double Protection and Safety

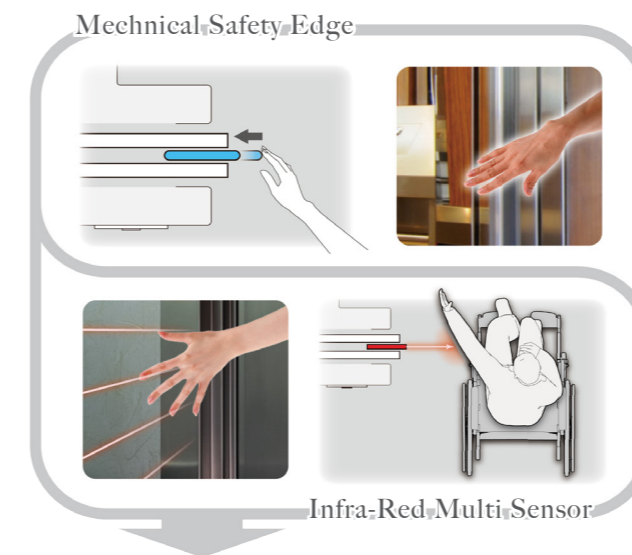

## EARTHQUAKE SENSOR

After severely earthquake of East Japan in 2011, Japan government regulates that all the elevators need to install earthquake sensors. When earthquake detects P waves, the elevators will be directed to the nearest floor in advance, evacuating passengers to prevent casualties.

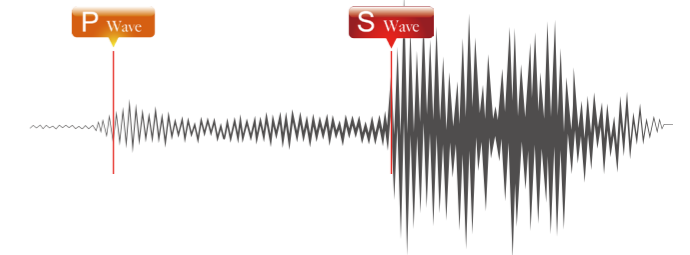



## STANDARD FUNCTION

Feature	Description
1.Power-on Re-leveling	In case of a power failure and cabin stop between floors, it will help cabins move to the nearest floor.
2.Emergency Car Lighting	During power failure, emergency lighting in cabins will automatically turn on.
3.Door Safety Detector	The door will detect obstructions. If it detected the lift will not return to normal operation until the fault has been rectified.
4.Safety Circuit Protection	When the lift electrical safety circuit is open the lift will immediately stop until the fault is rectified.
5.Cancel Error-Carry Function	If someone pushes a wrong button, it will be canceled by pushing it again.
6Automatic Turn-off Control Panel	If no one uses an elevator for a long time, it will be turned off automatically.
7Automatic Turn-off Fan	Fans will be turned off automatically if they are not in use for a long time.
8Automatic Turn-off Light	Cabin lights will be turned off automatically if it is not used for a long time.
9.Floor Standby	Elevators will be returned to the designated floor if it isn't not used for a long time.
10.Auto Time-extending Door Holding Function	If some one calls the cabin at a hall while others are walking out from the cabin, the door will be open for extra 5 seconds for passenger safety.
11.Door Nudging Feature	If an obstacle prevents the door from closing, the door will repeatedly open and close until the object is removed.
12.Overload Device	When an elevator is overloaded, it will stop the service until the load is within its capacity.
13.Anti-Nuisance	When an elevator detects excessive calls in a short amount of time, the elevator will determine if it is a prank. Then it will cancel all these wrong call to save energy.
14.Wrong Direction Cabin Call Back Canceling	When the car completes the last upward or downward direction change, the system will automatically detect and cancel the wrong direction call still stored in the memory.
15.Safety Operation	When a carbin stops between floors due to mechanical malfunction, it will descend to the nearest floor at a low speed and hold the doors open after checking all safety measures.
16.Safety Door Edge	The device can make the door reopen, if some one gets squeezed by the door.
17.Intercom System	Passengers in cabins are able to communicate with the control room through intercoms.

## OPTIONAL FUNCTION

Feature	Description
1.Automatic Malfunction Record	When an elevator malfunctions, for instance: safety circuit trips, electrical breakdowns, the system will automatically record the time and reasons.
2.Mannual System	Elevator can be switched between automatic and manual mode.
3.Auto Rescue Device(ARD)	When there is a power failure, ARD will use reserved electricity from batteries and drive cabins to the nearest floor.
4.Seismic Detector	If the seismic detection devise measures earthquake activity above a set value, the elevator will change to this emergency operation mode immediately. It will stop at the nearest floor and open the car door to disperse the passengers.
5.Fingerprint Reader	Instead of cards, fingerprint is used to call elevators.
6.GSM Notification System	This system monitors an elevator's operating conditions. If an elevator malfunctions, or some one is trapped inside a cabin, the system will notify the people in the calling list by SMS.
7.Remote Monitoring Function	It can transmit real time cabin condtions to monitors through WIFI or cables.
8.Elevator Monitor Platform	Computer software connects to controllers, monitoring elevator operation, breakdown records, change indicator's display, and set times for door open/close/hold/parameter setting/etc.
9.Security Code Call	It's the security code for a specific floor or person. Only the one who owns the code can reach the specified floor.
10.Voice Synthesizer	This system provides passengers with audio information about the car operation such as direction of travel, landing floor,etc.
11.Parking System	Parking system allows elevators to park when not in use. When activated, elevators will home to ground floors and automatically shut down for energy saving.
12.Skip Certain Floors	This function allows operators to make elevators skip certain floors.
13.Floor Priority Service	The call can be prioritized, meaning elevators can be set to go to designated floors first.
14.VIP Priority Service	When a call is made by VIP, elevators will go to his/her floors first.
15.Cabin Door Sensor	Door sensors are on both sides of cabin doors. When light beams are obstructed by objects, cabin doors will stay open.
16.Infrared Curtain	Infrared sensors are installed on hall doors and detect objects in front of hall doors. When there are no objects in front of elevators, doors will be closed automatically.
17.Infrared Curtain and Safety Edge	Infrared curtains and mechanical safety edges on both sides of door edges to prevent people from getting squeezed by doors.
18.Door Hold Button	This button prolongs door open time.
19.Arrival Bell	The bell (installed in cabins) will ring to notify passengers when elevators arrive.
20.Landing Arrival Bell	The bell (installed in halls) will ring to notify passengers when elevators arrive.
21.Hall Flashing Light	The lights glitter at halls right before elevators arrive.
22.Fireman Operational Device	When fire happens, firemen can use it to cancel all the calls and move elevators to designated floors for evacuation.
23.Fire return Operation	In case of fire every car will be returned to the specified floor in order to evacuate passengers safely.
24.Group Control System	The system controls up to 8 elevators and uses the most efficient ways to run elevators, reducing repeated stops and waiting time.
25.Selective Collective Operation	Can manage more than 2 elevators at once and adjust the usage of the peak/off peak time automatically so that it can reduce unnecessary operation while saving energy.
26Automatic Floor Support	When the first car is fully loaded , the next car will be automatically dispatched to serve passengers.
27.Overall Independent Lift Standby Function	When cabins complete all the calls, the system will anticipate future needs and dispatch individual cabins to the appropriate floors, then these cabins go into standby mode.
28.Peak Service	During peak hours, floors with heavy traffic will be given priority service.



## Machine Room Less

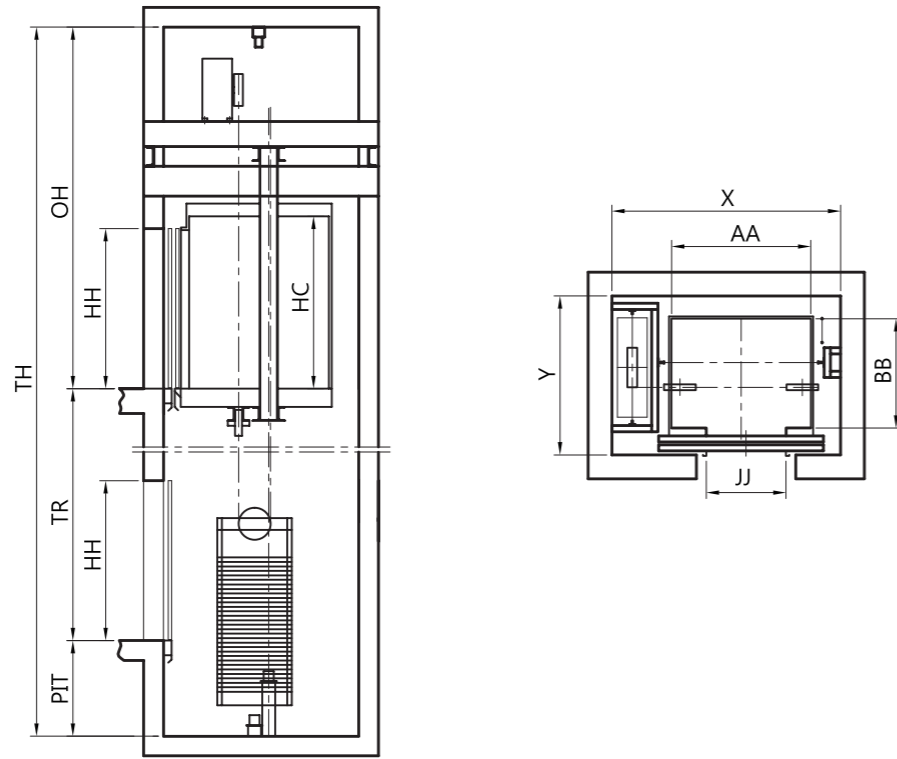

## Machine Room

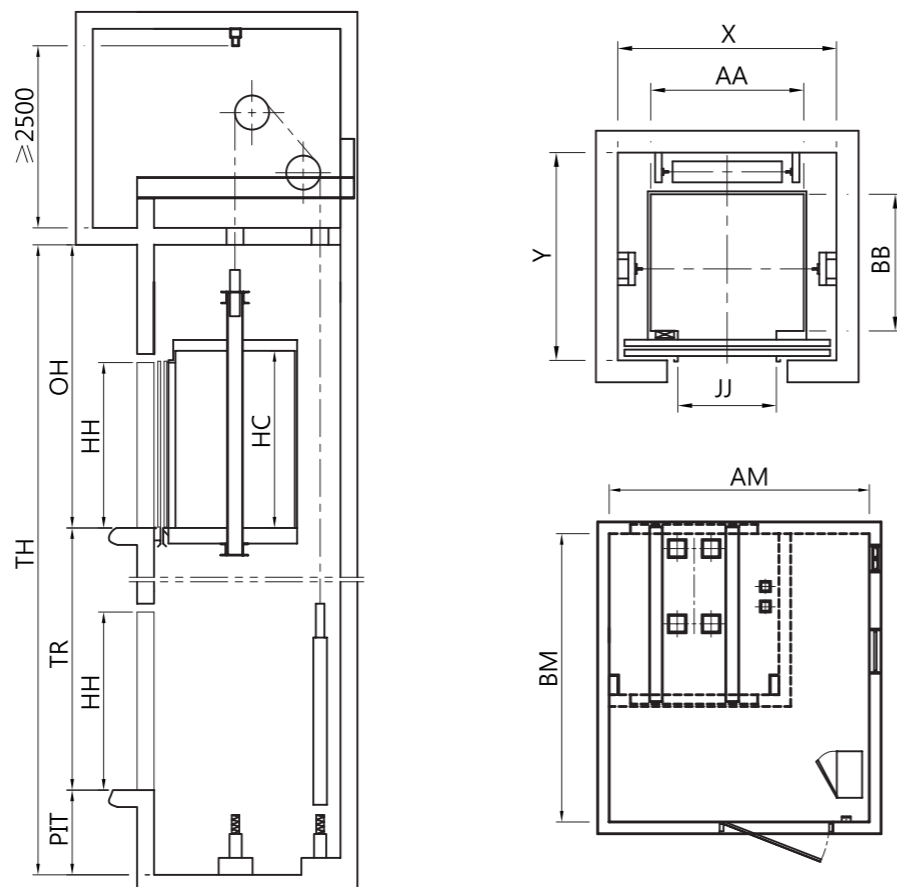

## Specification

TYPE	CAPACITY (KGS)	SPEED m/min	DOOR OPEN mm	ENTRANCE DIMENSION		CAR INTERIOR DIMENSION			HOISTWAY		MACHINE ROOM	
				JJ	HH	AA	BB	HC	X	Y	AM	BM
P	450	45-60	CO	800	2100	1400	850	2300	1750	1450	2000	2900
	550	45-105	CO	800	2100	1400	1030	2300	1750	1590	2000	3100
	600	45-105	CO	800	2100	1400	1100	2300	1750	1660	2000	32200
	700	45-105	CO	800	2100	1400	1250	2300	1750	1810	2000	3400
	750	45-105	CO	800	2100	1400	1350	2300	1750	1910	2000	3500
	820	45-105	CO	800	2100	1400	1400	2300	1750	1960	2000	3600
	900	45-105	CO	900	2100	1600	1350	2300	2100	1930	2500	3500
	1000	45-105	CO	900	2100	1600	1500	2300	2100	2080	2500	3700
	1150	45-105	CO	1100	2100	2000	1350	2300	2500	2100	2900	3800
	1350	45-105	CO	1100	2100	2000	1500	2300	2500	2250	2900	4100
1600	45-105	CO	1100	2100	2000	1750	2300	2500	2500	2900	4500	
EML-P	450	45-60	CO	800	2100	1400	850	2300	1800	1500		
	550	45-105	CO	800	2100	1400	1030	2300	1800	1700		
	600	45-105	CO	800	2100	1400	1100	2300	1800	1750		
	700	45-105	CO	800	2100	1400	1250	2300	1800	1950		
	750	45-105	CO	800	2100	1400	1350	2300	1800	2050		
	820	45-105	CO	800	2100	1400	1400	2300	1800	2100		
	900	45-105	CO	900	2100	1600	1350	2300	2100	2100		
	1000	45-105	CO	900	2100	1600	1500	2300	2100	2250		
	1150	45-105	CO	1100	2100	2000	1350	2300	2600	2200		
	1350	45-105	CO	1100	2100	2000	1500	2300	2600	2350		
1600	45-105	CO	1100	2100	2000	1750	2300	2600	2600			
EMS-P	450	45-60	CO	800	2100	1400	850	2300	1750	1450	1750	1450
	550	45-105	CO	800	2100	1400	1030	2300	1750	1590	1750	1590
	600	45-105	CO	800	2100	1400	1100	2300	1750	1660	1750	1660
	700	45-105	CO	800	2100	1400	1250	2300	1750	1810	1750	1810
	750	45-105	CO	800	2100	1400	1350	2300	1750	1910	1750	1910
	820	45-105	CO	800	2100	1400	1400	2300	1750	1960	1750	1960
	900	45-105	CO	900	2100	1600	1350	2300	2100	1930	2100	1930
	1000	45-105	CO	900	2100	1600	1500	2300	2100	2080	2100	2080
	1150	45-105	CO	1100	2100	2000	1350	2300	2500	2100	2500	2100
	1350	45-105	CO	1100	2100	2000	1500	2300	2500	2250	2500	2250
1600	45-105	CO	1100	2100	2000	1750	2300	2500	2500	2500	2500	

TYPE	ITEM	SPEED			
		45m/min	60m/min	90m/min	105m/min
P	OH(mm)	4200(4000)	4400(4100)	4600(4200)	4800(4300)
	PIT(mm)	1250(1350)	1550(1500)	1850(1800)	2150(1950)
EML-P	OH(mm)	3900(4000)	4100(4100)	4300(4200)	4500(4300)
	PIT(mm)	1250(1500)	1550(1600)	1800(1800)	2100(1950)
EMS-P	OH(mm)	5700(5500)	5900(5600)	6100(5700)	6300(5800)
	PIT(mm)	1250(1350)	1250(1600)	1850(1800)	2150(1950)







# Bed Lift

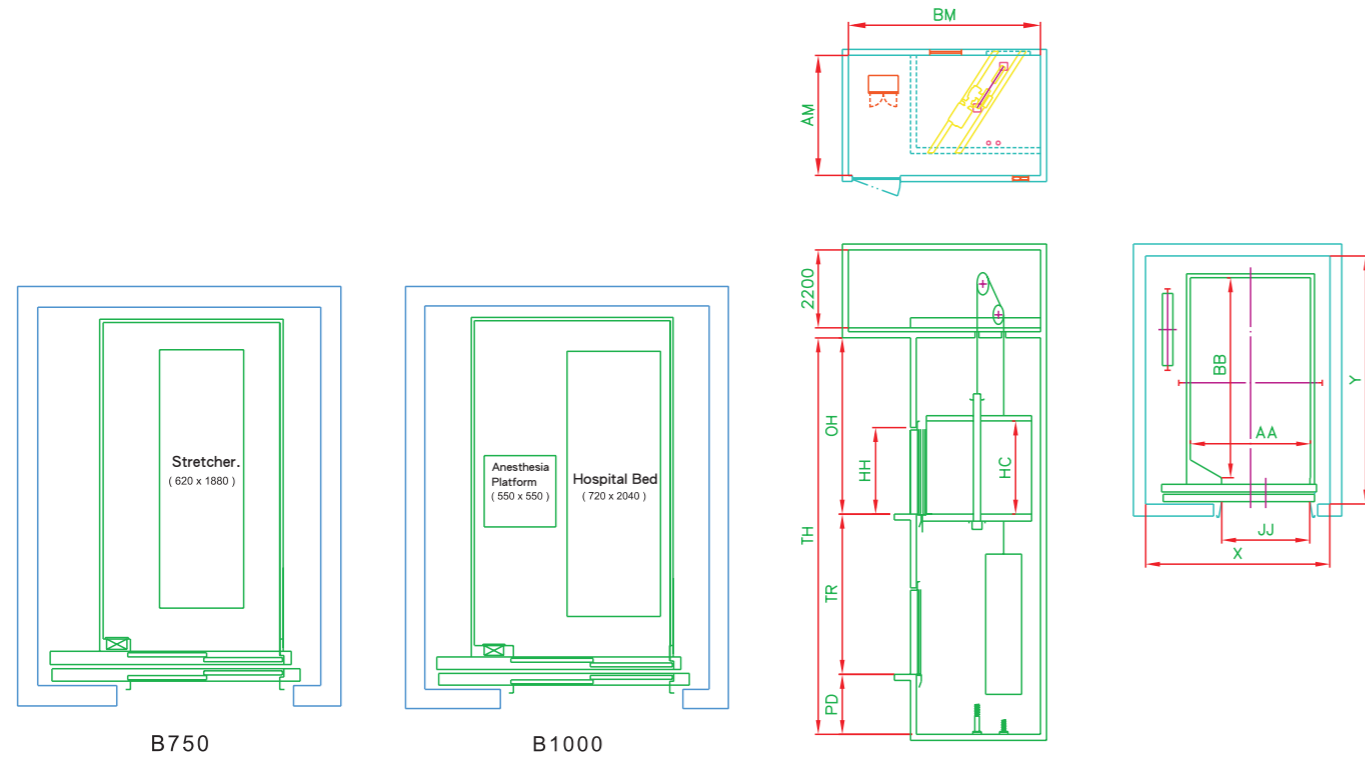

## Specification

TYPE	CAPACITY	SPEED	DOOR OPEN	ENTRANCE DIMENSION		CAR INTERIOR DIMENSION			HOISTWAY		MACHINE ROOM	
	(KGS)	m/min	mm	JJ	HH	AA	BB	HC	X	Y	AM	BM
B	750	45-90	2S	1100	2100	1300	2300	2300	2050	2900	2600	4600
	1000	45-90	2S	1100	2100	1500	2500	2300	2300	3100	3000	4800
EML-B	750	45-90	2S	1100	2100	1300	2300	2300	2150	2900		
	1000	45-90	2S	1100	2100	1500	2500	2300	2400	3100		
EMS-B	750	45-90	2S	1100	2100	1300	2300	2300	2050	2900	2050	2900
	1000	45-90	2S	1100	2100	1500	2500	2300	2300	3100	2300	3100

TYPE	ITEM	SPEED				
		45m/min	60m/min	90m/min	105m/min	
B	OH(mm)	4200(4200)	4400(4200)	4600(4300)	4800(4500)	
	PIT(mm)	1250(1350)	1550(1500)	1850(1800)	2150(1950)	
EML-B	OH(mm)	3900(4200)	4100(4200)	4300(4300)	4500(4500)	
	PIT(mm)	1250(1550)	1550(1550)	1800(1800)	2100(2100)	
EMS-B	OH(mm)	5700(5500)	5900(5600)	6100(5700)	6300(5800)	
	PIT(mm)	1250(1550)	1550(1550)	1850(1850)	2150(2100)	

# Cargo Lift

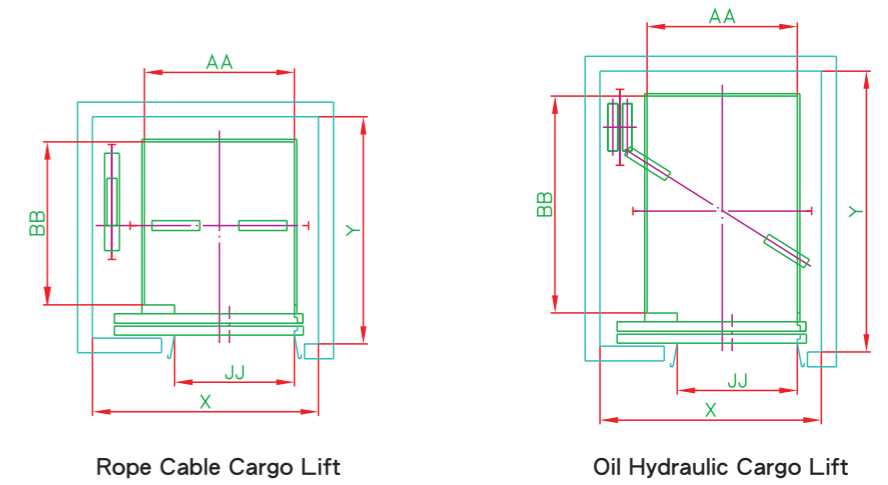

## Specification

TYPE	CAPACITY	SPEED	DOOR OPEN	ENTRANCE DIMENSION		CAR INTERIOR DIMENSION			HOISTWAY				MACHINE ROOM				
	(KGS)	m/min	mm	JJ	HH	AA	BB	HC	X	Y	PIT	OH	AM	BM			
F Steel Cable Type	500	20-60	2S	1200	2100	1500	1200	2300	2250	1800	1400mm for speed below 45m/min, 1500mm for upon 60m/min	4450mm for speed below 45m/min, 4850mm for upon 60m/min	3350	2900			
	600	20-60	2S	1100	2100	1350	1750	2300	2200	2400			3150	3800			
	750	20-60	2S	1200	2100	1550	2000	2300	2300	2600			3350	4000			
	1000	20-60	2S	1500	2100	1800	2200	2300	2700	2800			3600	4600			
	1500	20-60	3S	2300	2300	2300	2500	2300	3500	3100			4000	4500			
	1500	20-60	2U	2300	2300	2300	2500	2300	3250	3100			4000	4500			
	2000	20-60	3S	2300	2300	2300	3400	2300	3500	4000			5000	5500			
	2000	20-60	2U	2300	2300	2300	3400	2300	3250	4000			5000	5500			
	3000	20-45	2CO	2800	2500	2800	3700	2500	4550	4250			1500	4850	5500	6500	
	3000	20-45	3U	2800	2500	2800	3700	2500	3800	4400			1500	4850	5500	6500	
	4000	20-45	2CO	2800	2500	2800	4300	2500	4550	4850			1500	4950	6000	7000	
	4000	20-45	3U	2800	2500	2800	4300	2500	3850	5000			1500	4950	6000	7000	
	5000	20-45	2CO	2800	2500	2800	5500	2500	4550	6050			1600	4950	6500	7500	
	5000	20-45	3U	2800	2500	2800	5500	2500	3900	6200			1600	4950	6500	7500	
	F Indirect Hydraulic Type	500	15-45	2S	1200	2100	1500	1200	2300	2300			1800	1600	3750	3200	2500
		600	15-45	2S	1100	2100	1350	1750	2300	2150			2400	1500	3750	3200	2500
750		15-45	2S	1200	2100	1500	2000	2300	2300	2600	1500	3750	3200	2500			
1000		15-45	2S	1500	2100	1800	2200	2300	2750	2800	1500	3750	3200	2500			
1500		15-45	3S	2300	2300	2300	2500	2300	3600	3100	1550	3800	3300	2500			
1500		15-45	2U	2300	2300	2300	2500	2300	3400	3100	1550	4400	3300	2500			
2000		15-45	3S	2300	2300	2300	3400	2300	3600	4000	1600	3800	3300	2500			
2000		15-45	2U	2300	2300	2300	3400	2300	3400	4000	1600	4400	3300	2500			
3000		15-30	2CO	2800	2500	2800	3700	2500	4550	4250	1800	4750	3500	2600			
3000		15-30	3U	2800	2500	2800	3700	2500	3900	4400	1800	4750	3500	2600			
4000		15-30	2CO	2800	2500	2800	4300	2500	4550	4850	1800	4750	3500	2600			
4000		15-30	3U	2800	2500	2800	4300	2500	3950	5000	1800	4750	3500	2600			
5000		15-30	2CO	2800	2500	2800	5500	2500	4550	6050	1850	4900	3500	2600			
5000		15-30	3U	2800	2500	2800	5500	2500	4150	6200	1850	4900	3500	2600			



**JAPAN FUJI**  
INTERNATIONAL

For more information of JFI  
Please visit  
[www.fujilift.co.jp](http://www.fujilift.co.jp)

東京都港区三田一丁目2番18号TTDビル  
1-2-18, Mita, Minato-ku, Tokyo, 108-0073, Japan  
E-mail : [info@fujilift.co.jp](mailto:info@fujilift.co.jp)  
TEL : +81-3-45780389