

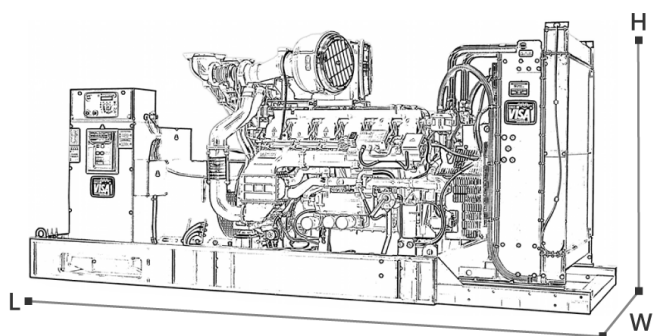

### POWERFULL "U"



For illustrative purposes only

#### ENGINE

Engine brand	MITSUBISHI
Engine model	S12R-PTA2
Cylinders	12
Speed	1500 r.p.m.
Cubic capacity	49.03 l
Air intake	Turbocharged
Standard voltage	24 Vdc
Optional voltage	Vdc
Sae	00-21
BMEP	1951 kPa
Cooling	Water
Flywheel P.R.P. Power	1195.0 kW
Flywheel Stand-by Power	1315.0 kW
Fuel Cons. at 100% (L.T.P.)	322.0 l/h
Fuel Cons. at 100% (P.R.P.)	290.0 l/h
Fuel Cons. at 75% (P.R.P.)	200.0 l/h
Fuel Cons. at 50% (P.R.P.)	157.0 l/h
Fuel Cons. at 25% (P.R.P.)	91.0 l/h
Electronic regulator	Standard
Precision class	A1
Oil quantity	180.0 l
Engine Antifreeze capacity	125.0 l
Radiator standard	?
Heat from radiator	698.0 kW
Heat from exhaust	816.0 kW
Heat from radiation	83.7 kW
Exhaust temperature	0 °C
Cooling air flow	1800.00 m <sup>3</sup> /min
Combustion air flow	95.00 m <sup>3</sup> /min
Exhaust gas flow	253.00 m <sup>3</sup> /min
TA Luft	Standard
TA Luft/2	Not available
EPA	Not available
Stage	Not available

#### MAIN DATA

Continuous power (PRP)	1360.0 (kVA)
Continuous power (PRP)	1088.0 (kW)
Stand-by power (LTP)	1455.0 (kVA)
Stand-by power (LTP)	1164.0 (kW)
Voltage • Frequency • Power Factor	380V • 50Hz • 0.8 cosφ
Sound pressure 7 m.	0.0 dBA

#### DIMENSIONS AND WEIGHT

Width	2000 mm
Length	4530 mm
Height	2242 mm
Weight	11000 kg

#### ALTERNATOR

Alternator brand	STAMFORD
Alternator model	PI734B
P.R.P. Power	1360.0 kVA
L.T.P. Power	1455.0 kVA
Connection	Star
Phases	3PH+N
Winding	6 terminals winding 312
Terminal Number	6 nr.
IP Protection	23
Electronic regulator	MX341
Precision	1.0 ± %

#### BASEFRAME

Model	ST60
Standard tank	0 l
Optional tank	0 l
Oversized tank*	0 l

#### CANOPY & SILENCER

Canopy model	SENZA COFANO
Silencer model	----
Silencer outlet diameter	0.0 mm

Standard reference conditions temperature 25°C, altitude 100m asl, relative humidity 30%, atmospheric pressure 100 kPa (1 bar), power factor 0.8 lag, balanced load - non distortional. Fuel consumption is nominal and refers to specific weight 0,850kg/l. Sound power values refer to free field conditions: the installation site may influence the values. Dimensions, weights and other specifications contained in the technical data sheet and related attachments are nominal, subject to tolerances and refer to the model with standard equipment; any optional and additional equipment/accessories can modify weight, dimensions, performance.

**P.R.P. Prime Power-Continuous power at variable load:** The power that a genset can supply in continuous service at a variable load for an unlimited number of hours per year while respecting the maintenance intervals established in the environmental conditions stated by the Manufacturer. according to ISO8528-1. The average power supplied over time and any applicable overload must be less than the percentages stated by the Manufacturer.

**L.T.P. Limited-time running power-Limited power:** The maximum power that a genset can supply for a limited time respecting the maintenance intervals established in the environmental conditions stated by the Manufacturer according to ISO 8528-1. The number of hours per year is stated by the Manufacturer. Overload is not permitted.

The data contained in this document is nominal and refers to the standard equipped model and is not binding. Visa S.p.A. reserves the right to revise the information without notice per our policy of continuous product development and improvement.

